

## WS-5C Aerial-mount Sensor/Controller – Data Sheet      GENERAL PRODUCT INFORMATION

The WS-5C rain and/or snow sensor activation device is designed for economical and effective control of heating cables in residential and commercial snow and ice melting applications. Built for bigger heating loads, the WS-5C regulates cable operation in driveways, sidewalks, ramps and more as a standalone controller or as a sensor for larger heating systems. The unit is housed in a sturdy NEMA 3R enclosure rated for outdoor use, and all internal electronic components are specified for -40°F (-40°C) to 185°F (+85°C) operation.

### FEATURES INCLUDE:

- Automatic Activation for Energy Efficient Operation
- Provides Reliable Rain and Snow Detection
- Dual Control Relay – Full 30A @ 277 VAC, 20A @ 28 VDC
- Input Power – Universal 100-277 VAC 50/60 Hz Operation
- Replaceable Remote Precipitation Sensor
- Easy Installation, Full Access to Electronics
- Integral Precipitation Sensor
- Standard 3/4" NPT Conduit Hub, Includes 3/4" to 1/2" Reducer
- Adjustable Temperature Trigger Point
- Adjustable Delay Off Drying Timer with 30-90 Minute or 2-6 Hour Ranges
- Bright LED Power/Activation Indicator
- Simple Remote Control/Monitor Capability
- Selectable Low Temperature Cutoff with Unique "Recover" Mode
- External Manual On-Automatic-Standby Override Switch
- Smart "Manual On" Operates for One Delay Off Cycle
- High Power, Low Price



### SPECIFICATIONS

Dimensions:	4¾"x7"x2¾" (120 mm x 178 mm x 70mm)
Weight:	2 lbs. (0.9 Kg)
Supply Power:	100-277 VAC 50/60 Hz operation, Field selectable
Operating Temperature:	-40° to 185°F (-40° to 85°C)
Trigger Temperature:	34° to 44°F (1.1° to 6.6°C) adjustable
Enclosure Rating:	NEMA 3R
Delay Off:	30-90 minutes or 2-6 hour ranges, Field selectable
Load Capacity:	Dual Control Relay: Full 30A @ 277 VAC, 20A @ 28 VDC

## GENERAL INFORMATION AND PRINCIPLES OF OPERATION

The WS-5C unit is housed in a two gang PVC enclosure. The overall dimensions are 4¾" (120mm) x 7" (178mm) x 2¾" (70mm), and weighs 2 pounds. The user may access all electronics by removing the four front cover screws.

Wiring is performed by terminating your existing wiring to the pre-installed pigtails. The WS-5C can be powered from a 100-277 VAC 50/60Hz source. A green LED light shines through a lens on the cover of the WS-5C to indicate operational status.

All WS units operate by detecting environmental conditions through a base mounted temperature sensor and a heated precipitation sensor. When rain or snow lands on the precipitation sensor the traces are bridged, and a closure is detected. The heater then rapidly evaporates the moisture, clearing the sensor. The sensor for the WS-5C (and WS-2C) simply screws into the top of the unit's enclosure.

Peak power consumption is 15 watts. Input voltage selection is automatic. The unit provides a single 277VAC @ 30A normally open load contact set.

An environmentally sealed control switch is provided. The MANUAL ON function activates the controlled equipment for testing and special operational conditions. The AUTOMATIC position allows the WS-5C to handle all detections and control. The STANDBY/RESET position disables triggering and can

also be used to clear the delay off timer from true or test activation.

If the switch is placed in MANUAL ON for less than 2 seconds and then switched back to AUTOMATIC, the controller will execute one delay off cycle. This can be used to clear surfaces from small snow drifts or frost or hail buildup without the danger of leaving the system in a continuous MANUAL ON condition. STANDBY/RESET can still be used to clear this DELAY-OFF cycle.

The DEL configuration switch activates the DELAY-OFF drying cycle timer on the WS-5C. The timer allows the WS-5C to continue to operate and dry the heated surface through evaporation once precipitation has stopped.

The drying cycle reduces the chance of moisture left behind refreezing into ice. This timer is restarted by each sensor trigger. Therefore, the WS-5C will continue to operate as long as it is triggered, then for the DELAY-OFF period once the trigger clears. All "sensor" modes (DEL Off) provide a 2 minute DELAY-OFF time. When in CONTROLLER mode (DEL On) the Long Delay (LD) configuration switch determines the time span of the drying cycle. The DELAY-OFF time can be adjusted from 30- 90 minutes (LD Off) or 2-6 hours (LD On) using the DELAY OFF control.

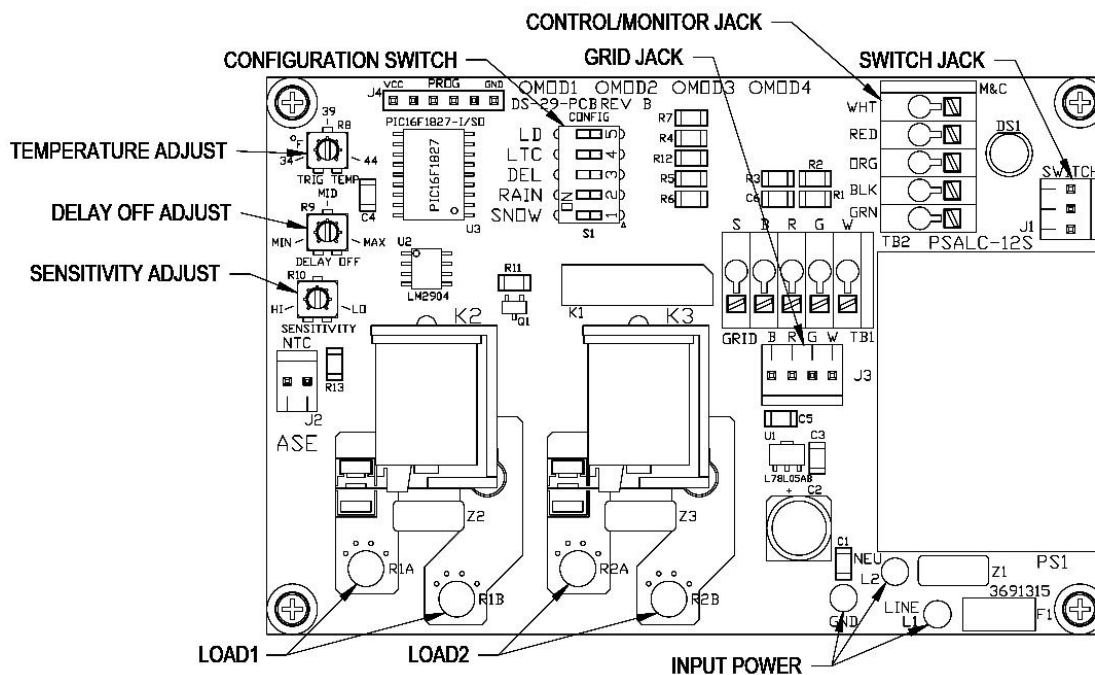

## Typical Application

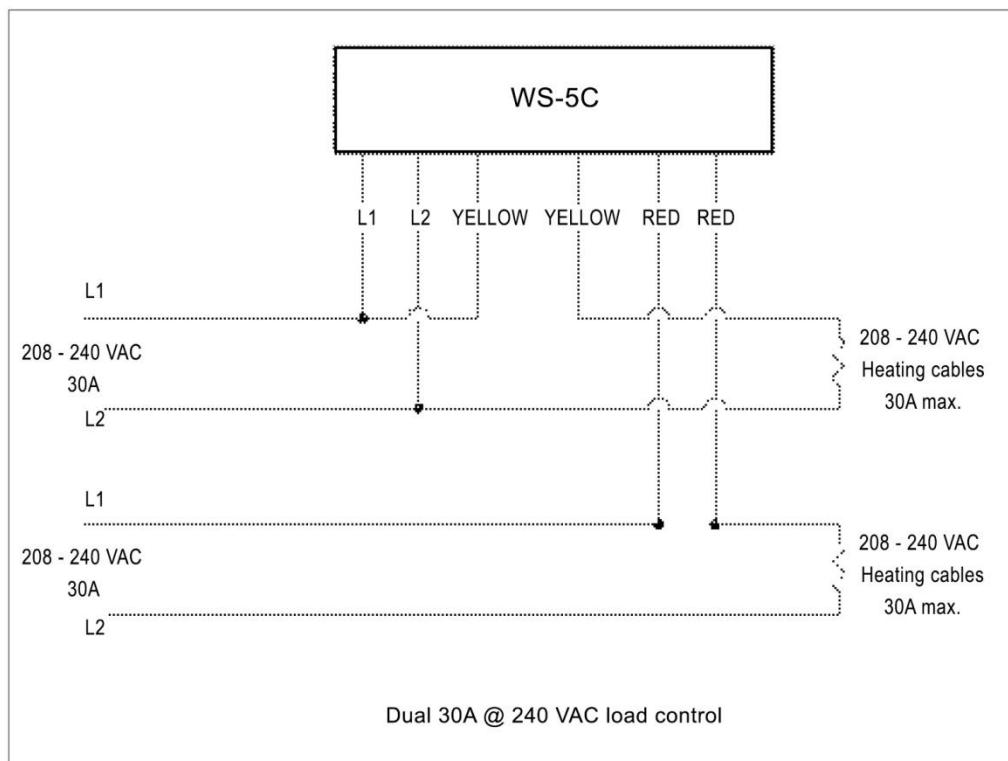

## TECHNICAL SUPPORT

For technical questions, please contact Warmzone at 888.488.WARM (9276) or via the web - [www.warmzone.com](http://www.warmzone.com).

## WARRANTY INFORMATION

The WS-5C is warranted against defects in workmanship and materials for 2-years from date of sale.

This warranty does not apply to damage resulting from accident, misuse, or alteration nor where connected voltage is more than 5% above the configured operating voltage, nor to equipment improperly installed or wired or maintained in violation of this Owner's Manual. No other written or oral warranty applies. No employee, agent, dealer or other person is authorized to give any warranties on behalf of ASE.

Units returned for warranty repair cannot be modified from shipped condition and leads must protrude a minimum of 6 inches from the base conduit hub. Repair costs of a modified unit will be quoted as the unit must be returned to the original, unmodified condition prior to return shipping. The customer shall be responsible for all costs incurred in the removal or reinstallation and shipping of the product for repairs. Within the limitations of this warranty, inoperative units should be returned, freight prepaid, to Manufacturer, and we will repair or replace, at our option, at no charge to you with return freight paid by Manufacturer. It is agreed that such repair or replacement is the exclusive remedy available from Manufacturer and that Warmzone IS NOT RESPONSIBLE FOR DAMAGES OF ANY KIND, INCLUDING INCIDENTAL AND CONSEQUENTIAL DAMAGE. Some states do not allow the exclusion or limitation of incidental or consequential damages so the above exclusion may not apply to you. The warranty gives you specific legal rights, and you may also have other rights which vary from state to state.

Warmzone accepts no responsibility for possible errors in catalogs, brochures, other printed materials, and website information. Warmzone reserves the right to alter its products without notice. This also applies to products already on order provided that such alteration can be made without subsequent changes being necessary in specifications already agreed upon. All trademarks in this material are property of the respective companies. All rights reserved.