

In-Slab

Floor Heating System

Installation & Operation Manual



WARMZONE 
PREMIER RADIANT HEATING

Table of Contents

1. In-Slab Heating System	3
2. Installation Conformity	3
3. Safeguards and Warnings – Important Information	4
3.1 Circuit.....	4
4. Approved Installations	5
4.1 1½ inches (3.81 cm) Concrete Membrane.....	5
4.2 4-6 inch (19.16-15.24 cm) Concrete Slab	5
4.3 Shower.....	5
4.4 Heating Cable vs. Impediments and Barriers	5
4.5 Humid Environments.....	6
4.6 Flooring.....	6
5. In-Slab Storage 6-watt Heat Cable and Mat Specifications	6
In-Slab Heating Cable off the Spool 240V.....	7
In-Slab Heating Mats 240V	8
6. Surface Preparation.....	8
6.1 Metal Mesh	9
7. General In-Slab Installation Instructions.....	9
7.1 Mat and Cables.....	9
7.2 Installation of the Heating Cable on the Concrete Reinforcing Bar	9
7.3 Heating Mat Modification.....	9
8. Detailed In-Slab Installation in a Concrete Slab	11
8.1 Plan Design.....	11
8.2 Drafting the Installation.....	11
8.3 Floor Sensor and Conduit Installation.....	11
8.4 Cable Installation.....	11
8.5 Casting the Concrete Slab	12
8.6 Connecting the Power Supply and Thermostat.....	12
9. Recording the Information and Applying the Labels	12
10. Adjusting In-Slab Heat Comfort.....	14
11. Cable Verification Tests	14
11.1 Measuring Resistance.....	14
12. Electrical Connection	15
12.1 Circuit.....	15
13. Non-Heating Cable (Cold Lead).....	15
Manufacturer’s Limited Warranty	16

1. In-Slab Heating System

This manual explains the process of installing the In-Slab™ heat cable and mat in concrete slabs. It is important to read and thoroughly understand this manual – as well as the thermostat's manual – before proceeding with the installation. For further details, please contact technical support; and for free installation training, please call 801-948-7577.

Any floor heating system's safety and reliability depend upon design of a plan for installation of, and tests carried out on the cables. All instructions and guidelines contained in this manual are important. Please read and thoroughly understand this manual, and retain it for future reference.

The heating cable system is designed for the sole purpose of heating under a floor. This system must be installed exclusively by certified professionals familiar with the floor heating system's dimensions, installation, construction, constraints, electrical hook-up, and operation, and aware of all associated risks.

2. Installation Conformity

Installation must be performed according to the manufacturer's instructions and the National Building Code of Canada, and in accordance with standards of a local electrical code in effect. Installation must comply with part 426 of the ANSI/NFPA 70 (American National Standards Institute / National Fire Protection Association) standard, NEC (National Electrical Code [NFPA 70]), and the Canadian Electrical Code (CEC) (CSA C22,1 Part 1). You must use a ground fault circuit interrupter (GFCI).

All building and electrical codes currently in effect must be complied with regardless of instructions provided in this manual. If any rules in any of these codes contradict any instructions in this manual, please immediately contact your provider.

All metal structures or materials used for supporting or installing the slab heating system must be grounded in accordance with division 10 of CSA standard C22.1, and with the NEC. It is recommended to install the In-Slab cable

or mats with a temperature limiting device integrated into the control as well as a ground fault circuit interrupter (GFCI). APPROVALS: CSA; EQUIPPED HEATING CABLE, IN SERIES TYPES G AND W IN CANADA AND TYPE C IN THE U.S.A.

This system can be used as a main heating source. The room's heat loss must be lower than the heating system's power. The thermostat can be set for the floor sensor or the room temperature. Refer to the thermostat's instructions for further information.

This product must be installed by a qualified person according to instructions in this installation manual and in conformity with either the Canadian Electrical Code (CEC), Part 1 or the U.S.A.'s National Electrical Code (NEC) as the case may be. All electrical connections must be performed by a qualified electrician in keeping with building and electrical codes currently in effect in your region.

This floor heating system, an electrical product certified for both dry and wet (shower) environments, must be installed in agreement with local electrical code and either Canadian (CEC) or National (NEC – U.S.A.) Electrical Code rules in effect in the municipality and either province or state where the system is to be installed.

You must also comply with requirements of and apply recommendations in the building code effective in the region where the system is to be installed. In addition, the NTCA and CTDA also issue useful installation recommendations that it is important to follow. This installation is of type C: buried floor

WARNING: Fire or Electrocutation Hazard

If the floor heating system is not installed according to instructions or the cable is damaged, there may be a risk of fire or electrocution.

heating.

Limited Warranty: Manufacturer warrants the heating cable for 10 years.

This limited warranty shall be valid only if the installer followed and applied the approved installation techniques and carried out all

conductivity tests on the cable. Please fill out the Test Log Sheet and the warranty form and send to Manufacturer.

Please refer to the warranty information on page 16.

3. Safeguards and Warnings – Important Information

- Before handling the cable in any way, shut the system off.
- If the cable system is damaged, it must be replaced. In this case, do not attempt to connect or repair any part of the system.
- For interior applications only.
- The system must be connected to a dedicated electrical circuit fitted with a ground fault circuit interrupter (GFCI).
- If you use the cable with the metal floor guides, approved spacings are 5 and 6 inches (6 being the standard).
- Never power the cable if it is on the inductor.
- Never install any cable designed for a 120V power supply on a 240V or 208V power supply.
- Never install the system under fixed furniture where no air circulates.
- Never install the cable on an expansion joint.
- It is important to comply with concrete drying times before energizing the system. Refer to the concrete manufacturer.
- Use copper connection cables.
- The thermostat must not be installed at any spot accessible from the bath or shower.
- Refrain from installing this product if the package seal on the box has been broken.
- The cable system must not extend or stick out of the room or area in which it is installed.
- Make sure the voltage provided matches that required for the In-Slab product.
- The cable must not be overlapped, cut, or modified.

- Never let the heating cable and floor sensor's cable cross each other.
- The cable's entire heating portion (including the splice) must be secured to the ground and covered with cement glue or a self-leveling coating.
- Never install the heating cable on or in any wall.
- Never submerge the cable.
- The sub-floor must meet or exceed requirements of the National Building Code or any other relevant rules and regulations in effect in your region for this type of installation.
- It is recommended to install a cable breakage detector all along the system's installation.
- The splice (junction between the cold lead and heat cable) must not be bent or folded.
- The cable splice must be completely buried in the concrete.

CAUTION: Never install the cable under a bulkhead, wall, or wall partition.

It is important to contact the flooring manufacturer to make sure that you are meeting their requirements concerning heating cable installation. In addition, the installer must follow and apply recommendations regarding any product installed under or over the heating cables.

3.1 Circuit

This floor heating system must be powered by a dedicated electrical circuit. The TOUCH thermostat's maximum current load is 15 amperes at 120 or 240 volts. If the installation requires more than 15 amps, it is possible to add an expansion unit or a second thermostat.

The system can be installed: onto insulation, plywood, a concrete floor, then covered with at least 1½ inches of concrete.



4. Approved Installations

4.1 1½ inches (3.81 cm) Concrete Membrane

The materials making up the subflooring in contact with the cable must have a service temperature of at least 194°F (90°C).

4.2 4-6 inch (19.16-15.24 cm) Concrete Slab

- High-density thermal insulation
- Sprayed polyurethane foam thermal insulation with a service temperature of at least 158°F (70°C)

4.3 Shower

The heating cable may be installed under a shower floor. The latter's surface tiles must be made of ceramic or natural stone. Additionally, a waterproof membrane must be installed under the surface tiles so the cable is kept dry. It is recommended to use an independent cable for this type of installation. In the U.S.A., the installation must adhere to standard NFPA 70 of the National Electrical Code (NEC) and/or other applicable codes, and must have received approval from local people in charge.

4.4 Heating Cable vs. Impediments and Barriers

- The heating cable must be installed at least 8 inches (20.32 cm) away from any heat source.
- Install the cable only if the surrounding temperature is over 40°F (5°C).
- The cable must be installed at a minimum distance of 3 inches (7.62 cm) from the base of any counter.
- The cable must be installed at a minimum distance of 6 inches (15.24 cm) from any outside wall.
- The cable must be installed at a minimum distance of 6 inches (15.24 cm) from any type of drain.
- The cable must be installed at a minimum distance of 10 inches (25.4 cm) from a toilet drain.
- The cable must be installed at a minimum distance of 8 inches (20.32 cm) from any

ground-secured heating system or apparatus.

- The cable must be installed at a minimum distance of 3 inches (7.62 cm) from any inside wall.
- The maximum length allowed for installing the cable on a straight line is 12 feet (3.657 m).
- There must be 2 inches (5.08 cm) of space between the floor surface and any fixed furniture.

The thermal heating principle consists of heating up a concrete slab using an electrical cable. It is very economical since the system uses the power outside heavy-usage hours. The slab stores and redistributes the heat, thus providing efficient, reliable, comfortable warmth throughout the day.

The In-Slab system offers several advantages in comparison with other heating systems:

- Low operating cost
- Easy, flexible installation combined with a single-connection point
- Increased, uncluttered floor area (no protruding heating units or boilers)
- Freedom to decorate (no forced-air heating ducts)
- Silent, risk-free, and effective operation
- Evenly spread heat, with no cold spots or patches
- Energy-efficient
- Cuts back on dust and allergenic substances
- Increased comfort

Versatile and easy to install, the In-Slab system is the optimal way of heating your home or commercial building.

NOTE: *The In-Slab floor heating system can be used as a sole heat source, and thus serve as the only heating system in the entire building.*

It is recommended to consult an engineer, architect or similarly qualified professional to make sure that the chosen In-Slab system is appropriate for intended use.

The perimeter of the space to be heated must be insulated with rigid expanded polystyrene (e.g., Styrofoam) at least 2 inches (5.08 cm) thick, or an equivalent suited for underground installation. Urethane and polystyrene foams

are unacceptable, since humidity curtails their insulation properties.

If the system is to be installed on crushed stone, it is preferable to first lay insulation onto the crushed stone. Use high-thermal density insulation. Refer to the local building code for rules and regulations on insulation.

If you wish to use a moisture barrier, install the mat/mesh or cable system onto it.

There must be no underground water at the construction site. The soil's natural humidity is acceptable. In case of doubt, please contact the Manufacturer.

4.5 Humid Environments

- Never make any connection to or other modification on the cable in a humid environment.

- Never initiate any installation in a wet environment. The connection cable and the joint must be entirely covered with concrete in a dry environment at least 1 inch away from the humid environment.
- The control/thermostat must not be accessible from a humid environment.

4.6 Flooring

The heating system is more effective when installed under ceramic, stone, or concrete flooring.

Should you decide to install carpeting, linoleum, hardwood, or other flooring material, please first consult the manufacturer of these flooring products to obtain the appropriate recommendations and warranties.

NOTE: Upon receiving the heat cable, it is important to check and record the resistance of each cable/mat using a digital ohmmeter. Compare the readings with the baseline resistance indicated on the stickers attached to the mats. If any mat shows a resistance reading that varies from the baseline value, call technical support at 801-948-7577. See Section 11 for more details.

5. In-Slab Storage 6-watt Heat Cable and Mat Specifications

Cable type	Coaxial cable (parallel)
Voltage (SW cables/mats/meshes)	240 volt
Power (SW cables)	5.5 watts per lin. ft. (18 W per m)
Power (SW mats/meshes)	11 watts per sq. ft. (118 W per sq. m)
Bend radius	1½ inches (38.1 mm)
Cable diameter	¼ inch (6.35 mm)
Conductor insulation	Fluoropolymer and XLPE
External insulation	PVC
Maximum temperature	220°F (105°C)
Minimum installation temperature	40°F (5°C)
Connection cable	10 feet (3 m) length





Specifications:

In-Slab Heating Cable off the Spool 240V

Item	Length		Coverage Area (Sq. Ft.)			Output		
			4-inch	5-inch	6-inch			
	Foot	Meter	16.5 W	13.2 W	11 W	Watts	Amps	Ohms
6CTS-240V-015	30	9.1	10.0	12.5	15.0	165	0.7	349.1
6CTS-240V-020	40	12.2	13.3	16.7	20.0	220	0.9	261.8
6CTS-240V-025	50	15.2	16.7	20.9	25.0	275	1.1	209.5
6CTS-240V-031	62	18.9	20.7	25.9	31.0	341	1.4	168.9
6CTS-240V-038	76	23.2	25.3	31.7	38.0	418	1.7	168.9
6CTS-240V-046	92	28.0	30.7	38.4	46.0	506	2.1	113.8
6CTS-240V-055	110	33.5	36.7	45.9	55.0	605	2.5	95.2
6CTS-240V-065	130	39.6	43.3	54.2	65.0	715	3.0	80.6
6CTS-240V-076	152	46.3	50.7	63.4	76.0	836	3.5	68.9
6CTS-240V-088	176	53.6	58.7	73.4	88.0	968	4.0	59.5
6CTS-240V-101	202	61.6	67.3	84.2	101.0	1111	4.6	51.8
6CTS-240V-115	230	70.1	76.7	95.9	115.0	1265	5.3	45.5
6CTS-240V-130	260	79.2	86.7	108.4	130.0	1430	6.0	40.3
6CTS-240V-146	292	89.0	97.3	121.8	146.0	1606	6.7	35.9
6CTS-240V-161	322	98.1	107.3	134.3	161.0	1771	7.4	32.5
6CTS-240V-177	354	107.9	118.0	147.6	177.0	1947	8.1	29.6
6CTS-240V-192	384	117.0	128.0	160.1	192.0	2112	8.8	27.3
6CTS-240V-207	414	126.2	138.0	172.6	207.0	2277	9.5	25.3
6CTS-240V-222	444	135.3	148.0	185.1	222.0	2442	10.2	23.6
6CTS-240V-237	474	144.5	158.0	197.7	237.0	2607	10.9	22.1
6CTS-240V-252	504	153.6	168.0	210.2	252.0	2772	11.6	20.8
6CTS-240V-267	534	162.8	178.0	222.7	267.0	2937	12.2	19.6
6CTS-240V-282	564	171.9	188.0	235.2	282.0	3102	12.9	18.6
6CTS-240V-297	594	181.1	198.0	247.7	297.0	3267	13.6	17.6
6CTS-240V-312	624	190.2	208.0	260.2	312.0	3432	14.3	16.8
6CTS-240V-325	650	198.1	216.6	271.1	325.0	3575	14.9	16.1



Specifications:

In-Slab Heating Mats 240V

Item	Length		Coverage Area (Sq. Ft.)	Output		
	Foot	Meter	6-inch spacing	Watts	Amps	Ohms
			11 Watts			
6MTS-240V-015	7.5	2.3	15.0	165	0.7	349.1
6MTS-240V-020	10.0	3.0	20.0	220	0.9	261.8
6MTS-240V-025	12.5	3.8	25.0	275	1.1	209.5
6MTS-240V-031	15.5	4.7	31.0	341	1.4	168.9
6MTS-240V-038	19.0	5.8	38.0	418	1.7	168.9
6MTS-240V-046	23.0	7.0	46.0	506	2.1	113.8
6MTS-240V-055	27.5	8.4	55.0	605	2.5	95.2
6MTS-240V-065	32.5	9.9	65.0	715	3.0	80.6
6MTS-240V-076	38.0	11.6	76.0	836	3.5	68.9
6MTS-240V-088	44.0	13.4	88.0	968	4.0	59.5
6MTS-240V-101	50.5	15.4	101.0	1111	4.6	51.8
6MTS-240V-115	57.5	17.5	115.0	1265	5.3	45.5
6MTS-240V-130	65.0	19.8	130.0	1430	6.0	40.3
6MTS-240V-146	73.0	22.3	146.0	1606	6.7	35.9
6MTS-240V-161	80.5	24.5	161.0	1771	7.4	32.5
6MTS-240V-177	88.5	27.0	177.0	1947	8.1	29.6
6MTS-240V-192	96.0	29.3	192.0	2112	8.8	27.3
6MTS-240V-207	103.5	31.5	207.0	2277	9.5	25.3
6MTS-240V-222	111.0	33.8	222.0	2442	10.2	23.6
6MTS-240V-237	118.5	36.1	237.0	2607	10.9	22.1
6MTS-240V-252	126.0	38.4	252.0	2772	11.6	20.8
6MTS-240V-267	133.5	40.7	267.0	2937	12.2	19.6
6MTS-240V-015	141.0	43.0	282.0	3102	12.9	18.6
6MTS-240V-020	148.5	45.3	297.0	3267	13.6	17.6
6MTS-240V-025	156.0	47.5	312.0	3432	14.3	16.8
6MTS-240V-031	162.5	49.5	325.0	3575	14.9	16.1

6. Surface Preparation

Prepare the surface that will accommodate the concrete slab in compliance with construction standards in effect in your region. Identify the room(s) to be heated, partition locations, expansion joints, and any barrier or hindrance to be bypassed (i.e., bottom drain, column, fixed furniture, etc.).

The cable shall be fixed to the metal mesh with plastic tie wraps. In order to maximize their performance, the cables should be embedded 1½ to 2 inches (3.81 to 5.08 cm) from the surface.

6.1 Metal Mesh

The metal structures used for securing the cables, or onto which the cables are to be installed, must be grounded in accordance with

the Canadian Electrical Code (CSA C22.1, Section 10) and the National Electrical Code.



7. General In-Slab Installation Instructions

7.1 Mat and Cables

If you use the cable floor guides (sold separately), follow the instructions below.

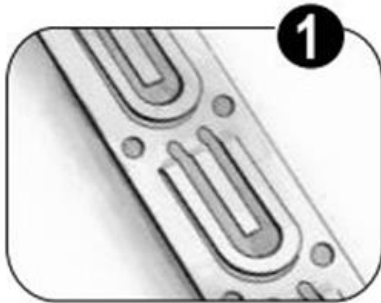

Secure the metal strapping to the ground (at a minimum distance of 6 feet (1.829 meters) between them).

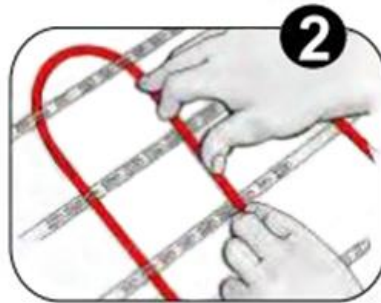

Install the cable at an ideal interval of 6 inches (15.24 cm).

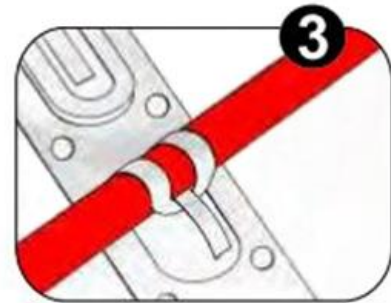

Secure the cable to the strapping.

7.2 Installation of the Heating Cable on the Concrete Reinforcing Bar

The cable must be installed with 6-inch spacing throughout the area to be heated.

Avoid tying the cable too tightly. Doing so may damage the cable.

The spacing between the floor guides should be about 6 feet (1.829 m) or less.

Should there be reinforcing bars or a mesh grid, then the floor guides become unnecessary. The heating cables can be fixed directly onto the rebar or mesh grid using tie wraps.

A concrete metallic reinforcement structure is needed for installing the cable. The latter must be installed respecting a 6-inch (15 cm) center spacing. Thus it is highly important to install a metallic reinforcement structure or mesh grid

that conforms with this spacing. For any other installation using a different spacing, please consult your system designer to obtain approval. The metallic mesh grid or reinforcement structure must be appropriately supported with cubes. We recommend a distance of 24 inches (60.96 cm) between the supports. Make sure to align the mesh leaves, overlap them by one complete square, and secure them using tie wraps. Cover sharp protrusions or any imperfection in the metal reinforcement structure with protective tape to prevent damaging the cable.

7.3 Heating Mat Modification

You can modify the mats to bypass structural elements, such as a drain. To make turns with the heating mat, simply cut the mesh backing. See the illustrations on the following page. (Never cut the heat cable.)

Turn Techniques

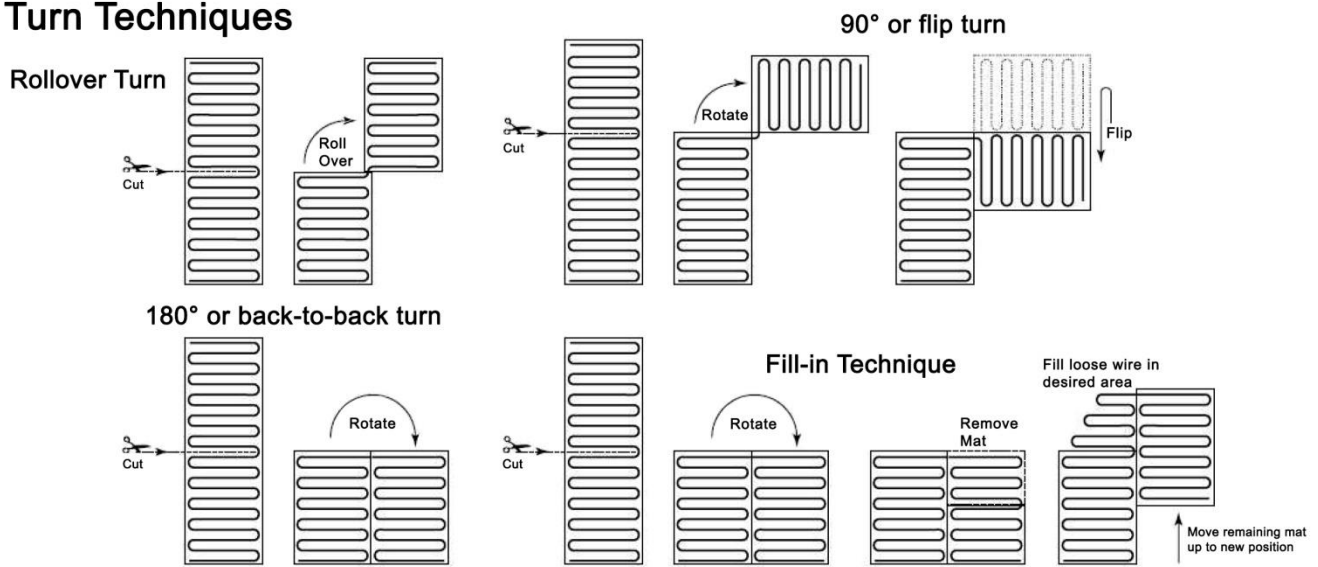

NOTE: Do not cut or damage the heating cable.

Start by fastening the mesh to the rebar with tie wraps. The cables must be secured, but not too tightly. Allow the mesh to be able to move a little. Roll out the mat to the point where it has to turn, then cut the mesh backing (adhesive tape) with scissors and arrange the next run of the mat. When aligning the new run of heating mat, be sure to space the cable properly from the previous row. (Refer to the

“Turn Techniques” schematic above for suggestions.)

When you cut the mesh backing, the heat cable can be removed from the adhesive tape and left loose. This gives the installer flexibility for installing the cable in curved spots, around drains, and close to other structural hindrances.

Typical Concrete Installation

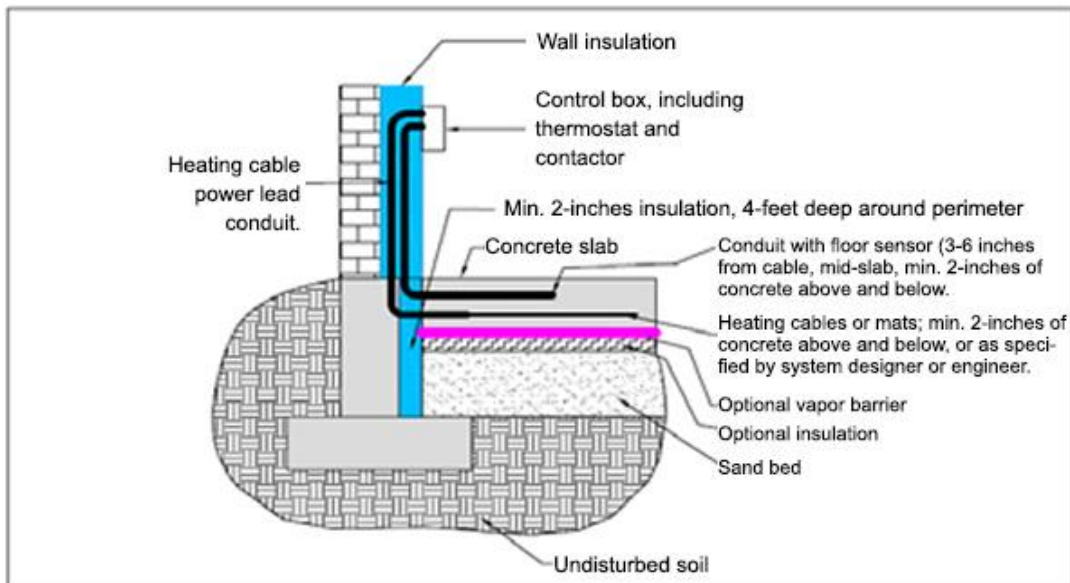

8. Detailed In-Slab Installation in a Concrete Slab

8.1 Plan Design

Determine locations for all drains, piping, electrical conduits and structural elements. Make sure to keep the cable at least 6 inches (15.24 cm) away from these elements. You must install all elements that will lie in the concrete slab before installing the cables, in order to prevent any damage to the cables.

Plan locations for the thermostat, sensors, and conduits. The starting point of the heating cable should be as close to the thermostat's location as possible.

8.2 Drafting the Installation

Using aerosol paint is a good means of drawing out your installation onto the insulation, plywood, or concrete. Indicate the walls that will limit rooms and systems. Each room should have its own system. Also point out all fixed objects, heat sources, piping, electrical outlets, and other elements you will have to avoid installing the system too close to.

8.3 Floor Sensor and Conduit Installation

It is preferable to install floor sensors in rigid conduits: a rigid conduit not only protects the sensor, but also facilitates its replacement should it be or become defective.

Sensor and conduit must be installed according to the construction plan and connected at a later date. Please take the following precautions:

1. Make sure the conduit is sealed before casting the concrete.
2. You must install the conduit between the heating cables, usually in the centre of the concrete slab.
3. It is recommended to keep the conduit as short as possible, and bend it as little as possible in order to facilitate the sensor's installation.
4. Place the sensor in the tube until it sticks out of the conduit by about 1 inch (2.54 cm).
5. Sensor and conduit must both be at a distance of 3 to 6 inches (7.62 to 15.24

cm) from the heating cables and surrounded by at least 2 inches (5.08 cm) of concrete or sand.

6. The floor sensor must be installed at least 3 feet 3.3 inches (1 m) into the heated area.
7. The floor sensor.
 - There is a sensor in the thermostat packaging.
 - Never install a sensor close to a heat or cooling source.
 - Check the sensor's operation using an appropriate device (consult the thermostat's instructions).
 - Never overlap a sensor with, or set it less than 2 inches (5.08 cm) from a heating cable.
 - The sensor must be installed at 1 inch (2.54 cm) from the concrete surface.

Secure the sensor directly in the middle between two heating cables. This will ensure accurate captures, and provide more accurate thermostat readings.

You must indicate this measure on the warranty card.

8.4 Cable Installation

The cable and mesh are usually fixed to the reinforcement structure or the foundation grid. When installing the cable, you may need tie wraps for the cable and mat/mesh. The cables should be set approximately in the middle of the slab's thickness; but anyway, in all cases, there has to be at least 1½ inches (3.81 cm) of concrete above the cable.

The power cable up to the junction and a minimum length of 12 inches (30.48 cm) of the power cable must be covered in concrete. The rest of the power cable must be in a conduit that reaches the thermostat or contactor. The power cable should be lengthened if necessary.

IMPORTANT NOTE: *It is recommended to photograph the cable's location, as well as the conduit's location during installation. This step will make it easier to repair the cables or lodge a claim.*

Use plastic Mesh-Ups to support the rebar and cables before casting the concrete.

Hold the cold lead cable and the two sensor wires and tie them together with rope or a clip to be fastened to a ceiling joist or any other suitable support.

Make sure the cold lead cable and the two sensor wires are long enough to reach the thermostat.

Connect the failure warning light to the cold lead, and switch it on if you proceed to immediately install the heating cable.

8.5 Casting the Concrete Slab

Cast the concrete slab. Make sure the concrete installation personnel exercise caution in their work and avoid damaging the cables with their tools, heavy machinery, etc. Once the slab has been cast and the concrete is still wet, measure the resistance and take note of the information on the warranty card. Wait about 30 days for the concrete to completely dry before energizing the cables. Check with the concrete manufacturer for exact drying time. In taking these precautions, you will ensure the slab's quality as well as the In-Slab cables' appropriate operation.

8.6 Connecting the Power Supply and Thermostat

Only a certified electrician used to handling heating cables must connect the thermostat in accordance with Canadian Electrical Code (CEC) and National Electrical Code (NEC) requirements.

Exercise caution in appropriately grounding the braided cable surrounding the heating cable.

Now, you have to make sure that the sensor is suitably installed in the conduit. The sensor must reach the conduit's sealed end. Connect the thermostat and sensor based on the thermostat installation manual's diagram.

Lastly, perform a final measure of resistance as outlined in Section 11 of this manual and take note of the information on the warranty card.

9. Recording the Information and Applying the Labels

Make sure that all resistance measurements taken have been recorded onto the warranty card.

The product number printed on the label of the In-Slab cable also has to be recorded onto the warranty card.

Install the electrical panel label onto the electrical panel to point out the cable's location.

Install the Warning label onto a visible area of the floor for the duration of construction.

We recommend keeping the cable's identification label in a suitable location for the duration of the warranty.



1

Thermostat



2

Cable ducts for cold lead

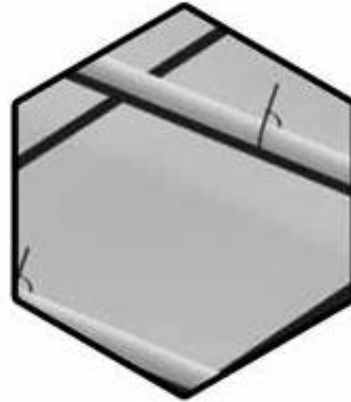

3

Secured with cable ties

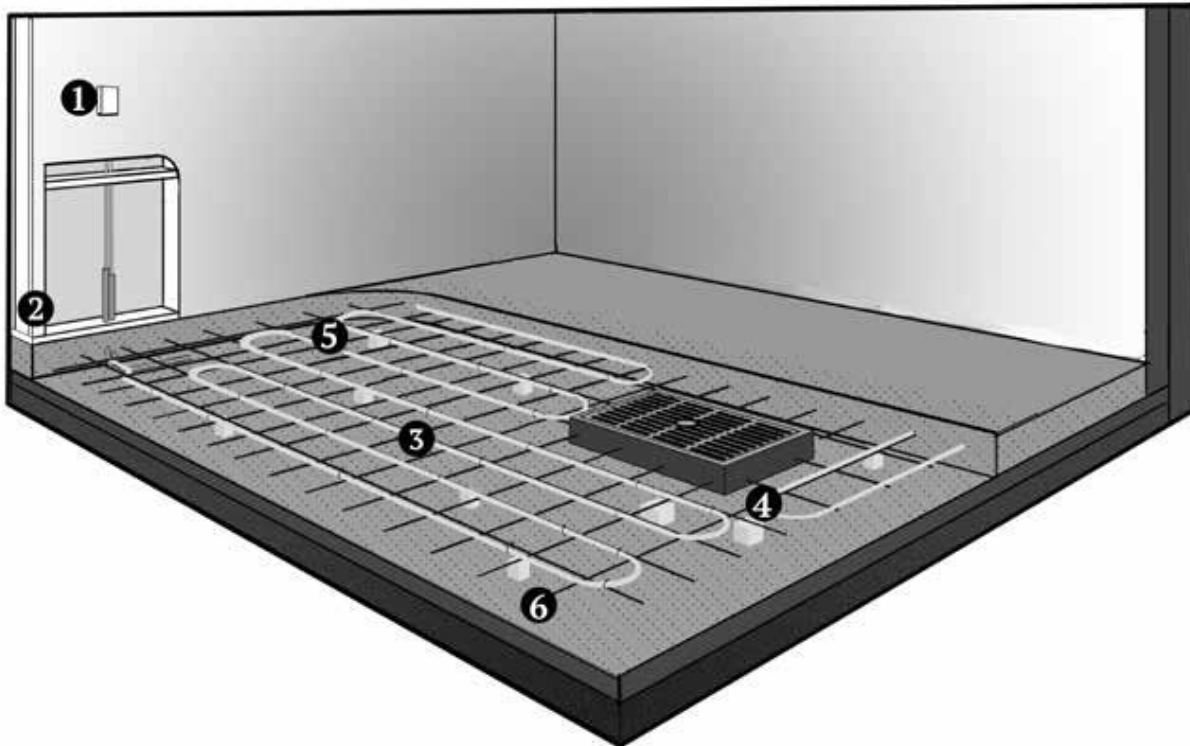

4

Floor fasteners

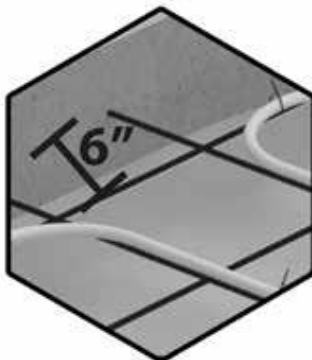

5

Clearance from drain and fixed obstacle

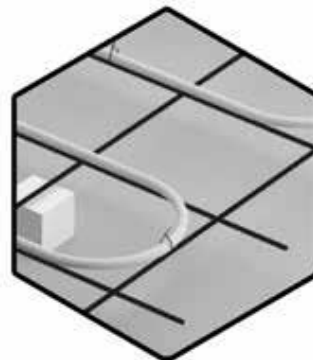

6

Clearance from exterior walls

10. Adjusting In-Slab Heat Comfort

The In-Slab heating system is now ready for use. Gradually increase the temperature at the thermostat and adjust it to the desired level.

Please note that there could be a delay of a few hours before the thermal mass warms up the floor upon first-time use or after a long inactivity period.

The majority of laminate and hardwood flooring manufacturers recommend that the heating system not be used at any temperature higher than 82°F to 84°F (27°C to 28°C). Please check this information with your flooring manufacturer.

11. Cable Verification Tests

Cable tests must be conducted by a qualified electrician.

The cable must be verified at every one of the five steps below in order for the customer to obtain the full warranty:

1. Upon receiving the cable and before breaking its protective plastic packaging
2. After installing the cable
3. After having covered the cable with concrete
4. After the flooring is installed
5. Before connecting the cable to the electrical network
 - Record the five tests' results onto the test log sheet.
 - The five cable testing steps must be recorded onto the test log sheet in order for the customer to obtain the full warranty.

The cable verification device below continually measures the heating cable's resistance throughout the installation process. If the cable gets cut or damaged during installation, the device will generate an audible signal. You must make sure that the device is operational before initiating the installation process; carry out a test with the cable by



disconnecting one of the three wires connected to the device. The audible signal should sound. If the device generates the audible signal during installation, stop all work and contact your provider.

11.1 Measuring Resistance

Each cable undergoes a 1,500V dielectric insulation test in the factory as well as a conductor resistance test.



Resistance must be measured between the white and black conductors using an ohmmeter or multimeter. Compare the resistance

measurement with the one printed on the product's label. If the multimeter is manual, adjust it to the 200-Ohm setting.



It is also compulsory to conduct the cable insulation test using a Megger® with its voltage setting adjusted to 1,000V. Measure

between the black and ground cables as well as between the white and ground cables to verify the cable's insulation. Both readings should show an infinite resistance. If there is a current leak between element and insulation, the device should display a value between zero and about 500 Ohms.



Record the resistance onto the test log sheet. You must record the resistance at each of the five cable verification steps in order for the warranty to remain valid.

If the amount of resistance does not match expected values (+/- 10%), the cable could be damaged and has to be repaired; in this case, please contact your provider to find out the procedures to follow.

You must also measure the floor sensors' resistance. They should be 10 kΩ at room temperature 77°F (25°C).

12. Electrical Connection

12.1 Circuit

Floor heating systems must be connected to a dedicated circuit. To determine the power of the circuit that will drive the system, see the power used up by the cable on its label.

The thermostat can take on a maximum current load of 15A. If your system requires over 15A, it will need more than one dedicated electrical circuit. Such a load necessitates an expansion unit. Refer to the thermostat's instructions manual for further information on expansion unit connection and operation.

Determine the location where the thermostat's junction box will be installed. It should be accessible, in the room where the system is to be installed, and at an appropriate height.

Use an Iberville #3004LH-RT (or equivalent product) type junction box for connecting the

system. Provide one box per circuit with a 15A current load. A 10-foot (3 m) length of non-heating cable (cold lead) is available at the end for connecting to the box.

13. Non-Heating Cable (Cold Lead)

The cold lead is connected to the heating cable by a mechanical joint (splice), which must also be buried in the concrete slab.

Locate the spot where the splice will be secured. It is recommended to insert the non-heating cable (cold lead) portion into an approved conduit installed in conformity with your region's electrical code. Afterwards, gently pull the cable until the splice is about 12 inches from the lower end of the conduit.

Manufacturer's Limited Warranty

For a period of ten (10) years from the date of purchase on electrical mats and cables and for a period of two (2) years on thermostats, sensors and controls (collectively "Product"), Manufacturer warrants to the original purchaser that the Product is free from defects in materials and workmanship under normal use and maintenance, provided the Product is installed in accordance with the accompanying installation manual, any special written design or installation guidelines for a particular project, the National Electrical Code (NEC) or the Canadian Electrical Code (CEC), and all applicable local building and electrical codes. The limited warranty is valid only if all measurements have been taken and recorded and the warranty certificate has been properly completed and mailed. Warranty is for Product only and does not cover any other equipment.

Under this Limited Warranty if the Product is determined by Manufacturer to be defective in materials and workmanship, has not been damaged as a result of abuse, misapplication, misuse, modification, neglect, alteration or improper installation, operation, maintenance, repair or testing, the Manufacturer will repair Product or supply replacement Product or refund the purchase price of the Product on Product covered by this Limited Warranty whichever Manufacturer may elect at its sole discretion.

This Limited Warranty does not cover and Manufacturer shall in no event be liable for:

1. Any direct, indirect, incidental or consequential damages, including inconvenience, loss of time, loss of or damage to or loss of use of facilities or other property, loss of revenue, loss of anticipated profits or loss of income.
2. Any labor or materials required to repair or replace the Product.
3. Any labor or materials required to remove, repair or replace covering materials.
4. Any freight or delivery costs related to the Product, or any related covering or electrical products.

Manufacturer assumes no responsibility under this warranty for any damage to the Product caused by any persons; including any trades people or owners or visitors to the job site or damage caused as a result of pre or post-installation work. Owing to differences in surfaces, applications, environment, climate and installation practices, Manufacturer makes no representation that application containing the products will be free from snow and/or ice.

MANUFACTURER DISCLAIMS ANY WARRANTY NOT PROVIDED HEREIN, INCLUDING ANY IMPLIED WARRANTY OF MERCHANTABILITY OR IMPLIED WARRANTY OF FITNESS FOR A PARTICULAR PURPOSE. MANUFACTURER FURTHER DISCLAIMS ANY RESPONSIBILITY FOR SPECIAL, INDIRECT, SECONDARY, INCIDENTAL, OR CONSEQUENTIAL DAMAGES ARISING FROM OWNERSHIP OR USE OF THIS PRODUCT, INCLUDING INCONVENIENCE OR LOSS OF USE. THERE ARE NO WARRANTIES WHICH EXTEND BEYOND THE FACE OF THIS DOCUMENT. NO AGENT OR REPRESENTATIVE OF MANUFACTURER HAS ANY AUTHORITY TO EXTEND OR MODIFY THIS WARRANTY UNLESS SUCH EXTENSION OR MODIFICATION IS MADE IN WRITING BY A CORPORATE OFFICER.

Some states do not allow the exclusion or limitation of implied warranties or liability for incidental or consequential damages, so the above limitation or exclusion may not apply to you. This warranty gives you specific legal rights, and you may have other rights, which vary from state to state.

Incoming materials should be inventoried and a resistance reading taken immediately for completeness and for possible shipping damage. Any visible damages or shortages must be noted prior to accepting the material. Any discrepancy concerning type or quantity of material shipped or Ohms measurements must be brought to the attention of Manufacturer or Manufacturer authorized agent within 15 days of the shipping date entered on the packing slip for the order.

How to Claim this Warranty

In order to receive the remedy set forth above, you must contact the manufacturer or manufacturer's authorized representative during the warranty period and include sufficient details relating to the nature of the defect, the installation, the history of operation, and any repairs that may have been made, including:

1. Provide Resistance readings taken by installer, Ohms measurement: within 4 hours before installing Product, after installing Product, and after covering is installed over Product.
2. Provide proof that Product was installed in accordance with the installation manual, any special written design or installation guidelines, the National Electrical Code (NEC) or the Canadian Electrical Code (CEC), and all applicable local building and electrical codes.
3. Provide dated proof of purchase.

Warranty Registration

Mail: PO Box 1268
Riverton, UT 84065
Phone: 801.948.7566